

EXAMINED BY : <i>Jony Chen</i>	EMERGING DISPLAY TECHNOLOGIES CORPORATION	FILE NO . CAS-10195
APPROVED BY: <i>David Chang</i>		ISSUE : NOV.15,1999
		TOTAL PAGE : 9
		VERSION : 1

CUSTOMER	ACCEPTANCE	SPECIFICATIONS
----------	------------	----------------

MODEL NO. :

24D40(CCFL TYPES)

FOR MESSRS :

CUSTOMER'S APPROVAL

DATE :

BY :

EMERGING DISPLAY
TECHNOLOGIES CORPORATION

MODEL NO . 24D40(CCFL TYPES)	VERSION 1
---------------------------------	--------------

RECORDS OF REVISION	DOC . FIRST ISSUE NOV.15,1999
---------------------	----------------------------------

DATE	REVISED PAGE NO.	SUMMARY

NUMBERING SYSTEM

Polarizer Mode	Backlight	Code value
Transflective	CCFL	D
Transmissive	CCFL	C

E W 24 D 40 B C W

LCD type + color	Code Value
STN + Blue	B
FSTN + White	F

TABLE OF CONTENTS

NO.	ITEM	PAGE
=====		
1.	GENERAL SPECIFICATIONS -----	1
2.	MECHANICAL SPECIFICATIONS -----	1
3.	ABSOLUTE MAXIMUM RATINGS -----	2
4.	ELECTRICAL CHARACTERISTICS -----	3
5.	TIMING CHARACTERISTICS -----	4
6.	OPTICAL CHARACTERISTICS -----	5
7.	OUTLINE DIMENSION -----	6
8.	BLOCK DIAGRAM -----	7
9.	DETAIL DRAWING OF DOT MATRIX -----	8
10.	INTERFACE SIGNALS -----	8
11.	POWER SUPPLY -----	9
12.	NUMBERING SYSTEM -----	10

1. GENERAL SPECIFICATIONS

1.1 GENERAL SPECIFICATIONS

PLEASE REFER TO :

CUSTOMER ACCEPTANCE STANDARD SPECIFICATIONS :

EU - 001A

1.2 APPLICATION NOTES FOR CONTROLLER :

PLEASE REFER TO :

CUSTOMER ACCEPTANCE STANDARD SPECIFICATIONS :

EU - 110

1.3 THIS INDIVIDUAL SPECIFICATION IS PRIOR TO GENERAL SPECIFICATIONS .

2. MECHANICAL SPECIFICATIONS

- (1) NUMBER OF DOTS ----- 240W * 128H DOTS
- (2) MODULE SIZE ----- 121.5W * 82.0H * 15.0D mm
- (3) EFFECTIVE AREA ----- 94.5W * 54.5H mm
- (4) ACTIVE AREA ----- 91.17W * 48.61H mm
- (5) DOT SIZE ----- 0.35W * 0.35H mm
- (6) DOT PITCH ----- 0.38W * 0.38H mm
- (7) LCD TYPE *
- (8) DRIVING METHOD ----- 1 / 128 DUTY MULTIPLEX DRIVE
- (9) VIEWING DIRECTION ----- 6 O'CLOCK
- (10) BACK-LIGHT ----- CCFL

* PLEASE REFER TO NUMBERING SYSTEM

3. ABSOLUTE MAXIMUM RATINGS

3.1 ELECTRICAL ABSOLUTE MAXIMUM RATINGS .

PARAMETER	SYMBOL	MIN .	MAX .	UNIT	REMARK
POWER SUPPLY FOR LOGIC	VDD — VSS	0	6.0	V	
INPUT VOLTAGE	VI	VSS	VDD	V	
STATIC ELECTRICITY	—	—	100	V	NOTE (1)

NOTE (1) : TEST METHOD AND CONDITIONS :
AFTER CHARGING UP 200 PF CAPACITOR BY STATED VOLTAGE ,
THE CAPACITOR IS CONNECTED WITH INTERFACE PINS OF THE
MODULE .

3.2 ENVIRONMENTAL ABSOLUTE MAXIMUM RATINGS .

I T E M	OPERATING		STORAGE		REMARK
	MIN .	MAX .	MIN .	MAX .	
AMBIENT TEMPERATURE	-20 °C	70 °C	-30 °C	80 °C	NOTE (2), (3) (4)
HUMIDITY	—	85 % RH	—	85 % RH	WITHOUT CONDENSATION
VIBRATION	—	2.45 m/s ² (0.25 G)	—	11.76 m/s ² (1.2 G)	10~100 HZ XYZ DIRECTIONS 1 Hr . EACH
SHOCK	—	29.4 m/s ² (3 G)	—	490.0 m/s ² (50 G)	10 mSECONDS XYZ DIRECTIONS 1 TIME EACH
CORROSIVE GAS	NOT ACCEPTABLE		NOT ACCEPTABLE		

NOTE (2) : Ta AT -30°C : 48HR MAX.
80°C : 168HR MAX.

NOTE (3) BACKGROUND COLOR CHANGES SLIGHTLY DEPENDING ON AMBIENT
TEMPERATURE THIS PHENOMENON IS REVERSIBLE .

NOTE (4) : CCFL BACKLIGHT IS NOT AVAILABLE TO FUNCTION BELOW 0°C.

5. INTERFACE TIMING CHARACTERISTICS

V_{CC} = 5.0 V

ITEM	SYMBOL	MIN	TYP	MAX	UNIT
Enable cycle time	t _{CYC}	1.0	—	—	μs
Enable pulse width	H LEVEL	t _{WEH}	0.45	—	μs
	L LEVEL	t _{WEL}	0.45	—	μs
Enable rise time	t _{Er}	—	—	25	ns
Enable fall time	t _{Ef}	—	—	25	ns
Setup time	t _{AS}	140	—	—	ns
Data setup time	t _{DSW}	220	—	—	ns
Data delay time	t _{DDR}	—	—	140	ns
Data hold time	t _{DHW}	20	—	—	ns
Address hold time	t _{AH}	10	—	—	ns
Data hold time	t _{DH}	20	—	—	ns

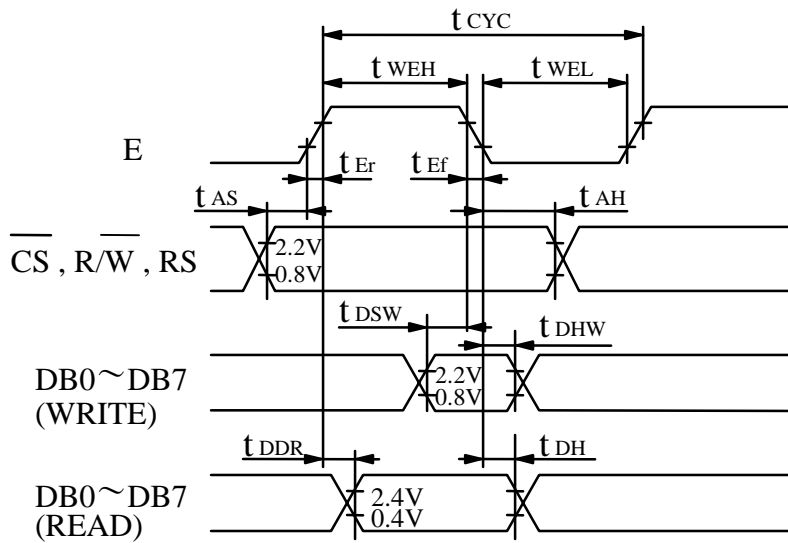

6. OPTICAL CHARACTERISTICS

Ta = 25 °C VDD = 5.0 V

I T E M		SYMBOL	CONDITION	MIN .	TYP .	MAX.	UNIT	NOTE
VIEWING AREA	STN	Ø2 - Ø1	K ≥ 2.0	40	—	—	deg.	1
	FSTN			50	—	—		
VIEWING AREA	STN	K	Ø = 10° θ = 0°	—	5	—	—	1
	FSTN			5	—	—		
RESPONSE TIME	tr(ri se)		Ø = 10° θ = 0°	—	240	—	ms	1
	tf(fall)			—	190	—	ms	1
BRIGHTNESS OF BACKLIGHT	B	—	—	55	—	—	cd/m²	2,4,5
				70	—	—		3,4,5
RISE TIME OF BACKLIGHT	TC	—	—	—	5	—	MINUTE	—
BRIGHTNESS UNIFORMITY	—	—	—	—	—	25	%	4,5

NOTE (1) : PLEASE REFER TO :
CUSTOMER ACCEPTANCE STANDARD SPECIFICATIONS.
E U - 002 A

NOTE (2) : POLARIZER MODE : TRANSFLECTIVE

NOTE (3) : POLARIZER MODE : TRANSMISSIVE

NOTE (4) : MEASUREMENT OF THE FOLLOWING 9 PLACES ON THE DISPLAY .
DEFINITION OF THE BRIGHTNESS UNIFORMITY

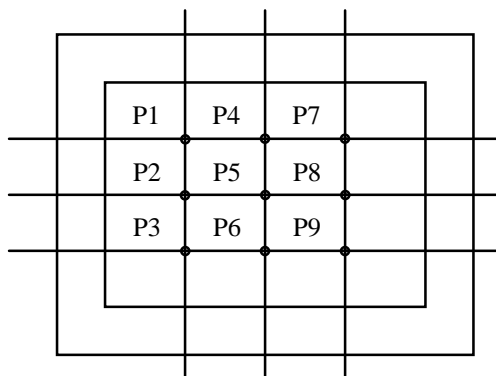

NOTE (5) : BRIGHTNESS UNIFORMITY IS DEFINED AS FOLLOWING

$$\sum X = \left[\frac{(\text{MAXIMUN BRIGHTNESS OR MINIMUN BRIGHTESS}) - \text{AVERAGE BRIGHTNESS}}{\text{AVERAGE BRIGHTNESS}} \right] \times 100\%$$

7. OUTLINE DIMENSION

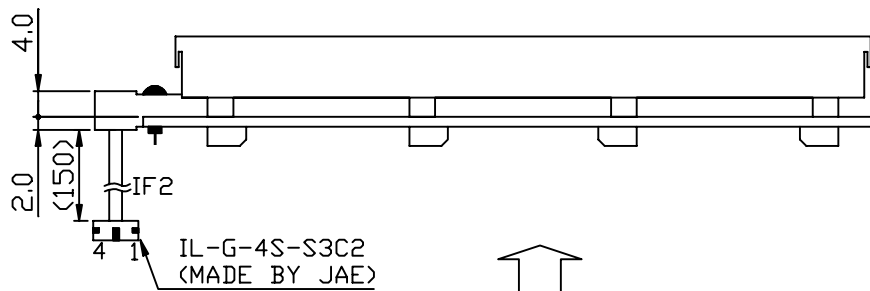
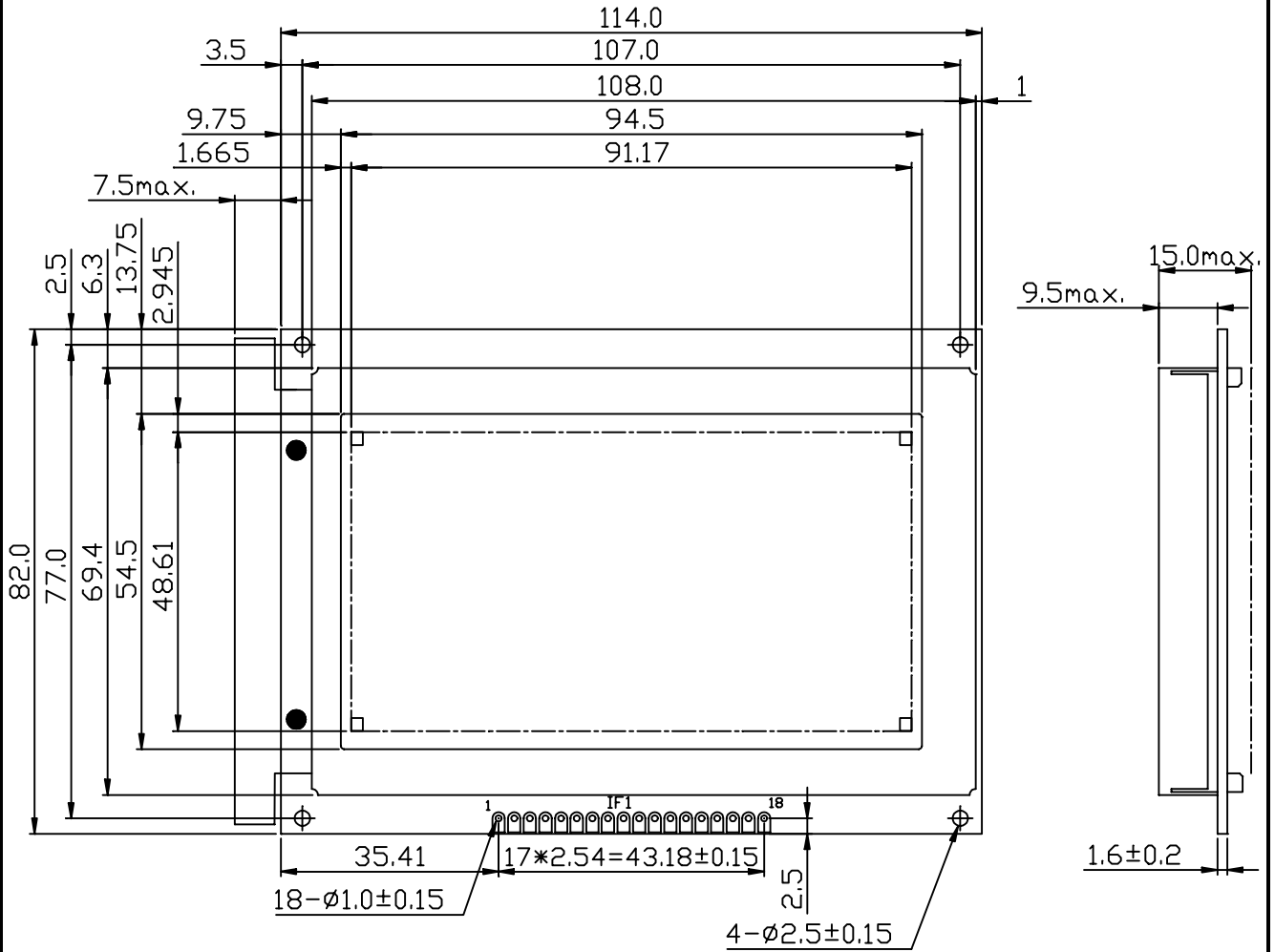

VIEWING DIRECTION (6 O'CLOCK)

UNIT : mm
SCALE : NTS
NOT SPECIFIED TOLERANCE IS \pm 0.5

8. BLOCK DIAGRAM

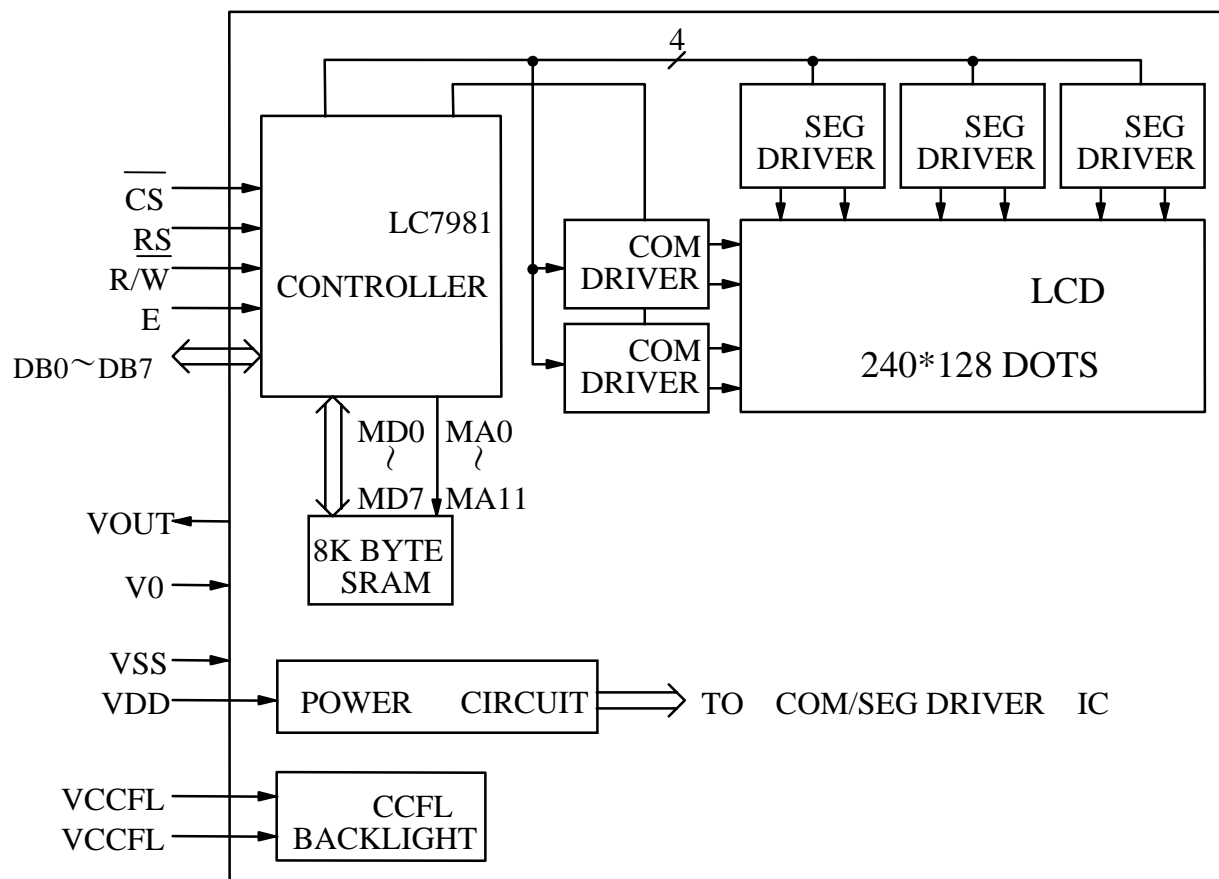

9. DETAIL DRAWING OF DOT MATRIX

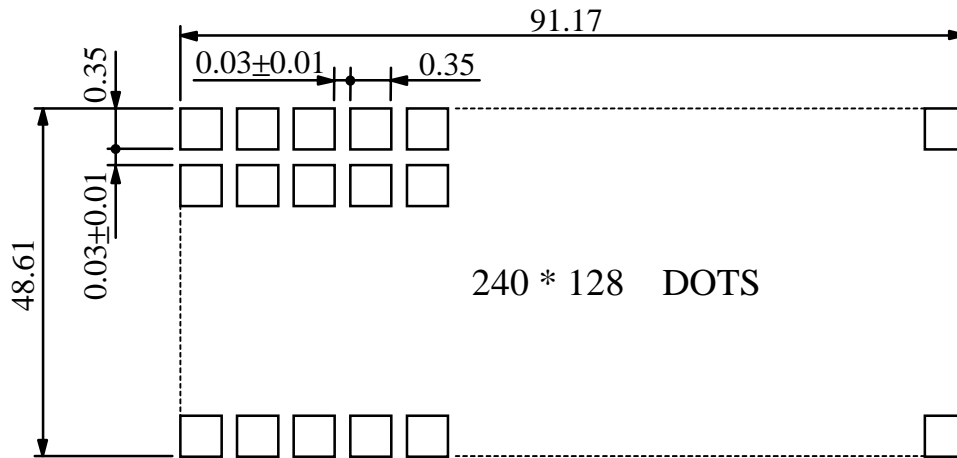

UNIT : mm
SCALE : NTS
NOT SPECIFIED TOLERANCE IS ± 0.1

10. INTERFACE SIGNALS

IF1:

PIN NO	SYMBOL	LEVEL	FUNCTION
1	N.C	—	NOT USE
2	N.C	—	NOT USE
3 10	DB0 DB7	H/L	DATA BUS LINE
11	RS	H/L	H : INSTRUCTION REGISTER L : DATA REGISTER
12	$\overline{R/W}$	H/L	H : DATA READ (LCD MODULE \rightarrow MPU) L : DATA WRITE (LCD MODULE \leftarrow MPU)
13	E	H \rightarrow L	ENABLE SIGNAL
14	VSS	—	GROUND
15	VDD	—	POWER SUPPLY FOR LOGIC CIRCUIT
16	\overline{CS}	L	CHIP SELECTION
17	VOUT	—	POWER SUPPLY FOR LCD DRIVER
18	V0	—	OPERATING VOLTAGE FOR LCD DRIVE

IF2 :

INTERFACE	PIN	SINGAL	LEVEL	FUNCTION
CCFL	1	VCCFL	—	POWER SUPPLY FOR CCFL DRIVING
	2~3	NC	—	NO CONNECTION
	4	VCCFL	—	POWER SUPPLY FOR CCFL DRIVING

1 1 . POWER SUPPLY

1 1 . 1 POWER SUPPLY FOR LCM

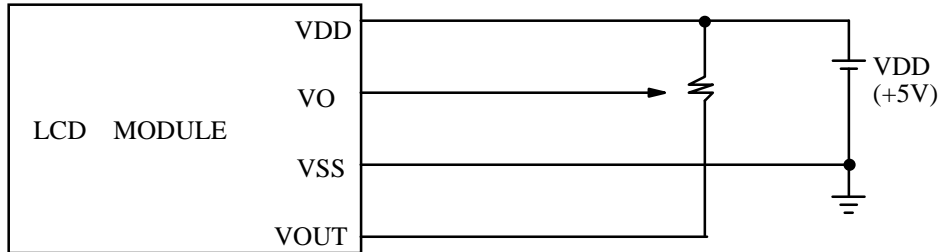

1 1 . 2 POWER SUPPLY FOR CCFL BACK - LIGHT

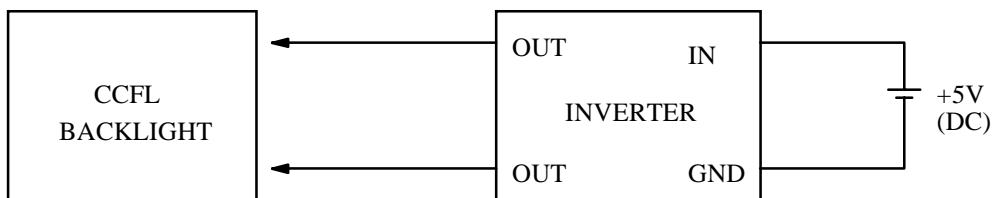

RECOMMENDED INVERTER : IA-EM02A

1 1 . 3 TIMING OF POWER SUPPLY AND INTERFACE SIGNAL

